 Heavy Industry

INDUSTRIAL VACUUM CLEANERS WITH

Lobe Pumps

 **DELFIN**
FOR A DUST-FREE WORLD

DISCOVER THE NEW COMPACT RANGE: POWER, EFFICIENCY, AND COMPACT DESIGN

The new COMPACT range is designed to deliver maximum performance in a reduced format, ensuring efficiency, reliability, and ease of use in any industrial environment. This product range combines advanced technology and high-quality materials to offer a powerful maneuverable solution.

KEY FEATURES

- Compact and robust design: ideal for limited spaces without compromising performance.
- Guaranteed power: high-performance motors and pumps designed for intensive use.
- Optimized discharge: on tank version, removable container for ease of emptying through bottom bottom hatch.
- 1000L container capacity.
- High mobility: designed for easy movement within the production facility.
- Automatic filter cleaning system and long-lasting filter fabrics with protective coating.

With the perfect combination of power, efficiency, and compactness, the DELFIN COMPACT range represents the ultimate solution for those looking for a reliable and high-performing suction to maintain efficient and clean the production lines

NEW COMPACT RANGE



INDUSTRIAL VACUUMING CLEANERS FOR HEAVY INDUSTRIES

Delfin DHV industrial vacuum cleaners are the most effective solution for the maintenance needs inside heavy industry production plants, allowing safe and easy handling of large quantities of dusts and solids.

- Vacuums engineered for heavy and continuous duty
- Highly performant and long-lasting products
- High filtration efficiency
- Several customized solutions available upon request
- High autonomy of the system
- Low noise level
- Easy to set up and to maintain



COMPACT TANK
with 1.000 lt detachable container

COMPACT HOPPER
with 1.000 lt hopper
and butterfly discharge valve

DHV TANK
with 800 lt detachable
container

DHV HOPPER
with 1.000 lt hopper
and butterfly discharge
system

		CP 22AF	CP 22HV	CP 30AF	CP 37AF	CP 37HV	DHV 30AF	DHV 30HV	DHV 45AF	DHV 45HV
Power	kW	22	22	30	37	37	30	30	45	45
Max Water lift		5.000	7.500	5.000	5.000	7.200	5.000	7.500	5.000	8.500
Air flow	m ³ /h	1.300	1.100	1.700	2.000	1.500	1.800	1.300	2.300	1.700
Main filter	cm ₂	120.000	120.000	120.000	120.000	120.000	180.000	180.000	180.000	180.000
Safety filter	cm ₂	40.000	40.000	40.000	40.000	40.000	70.000	70.000	70.000	70.000

BENEFITS



WASTE REDUCTION
Recovery of leaks and spillages with a recycling process
Increase of product quality



DOWNTIMES REDUCTION
Prevention of breakdowns and increase of plant lifetime, thus reducing spare parts buying costs



PRODUCTION EFFICIENCY
Maximum production capacity and efficiency thanks to the regular maintenance of the plants



SAFE AND HEALTHY WORKING ENVIRONMENTS
Injury reduction and minimization of diseases caused by the constant presence of dust

OPTIONAL



CONTROL PANEL BOARD
WITH HMI DISPLAY ON
DHV LINE

DHV OPERATING PRINCIPLE

A powerful pump with tri-lobe rotors generates the vacuum, which allows to vacuum large quantities of heavy materials. A set of highly efficient sleeve filters protects the pump while separating air from the recovered material, which falls into the collection unit.

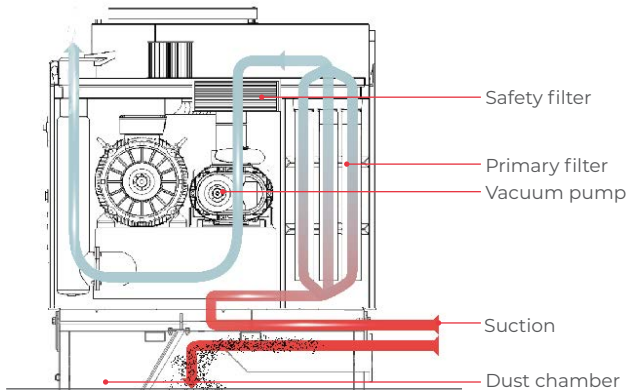

HIGH VACUUM LOBE PUMPS

Self-cooling lobe pumps generate very high waterlift and air flow values.

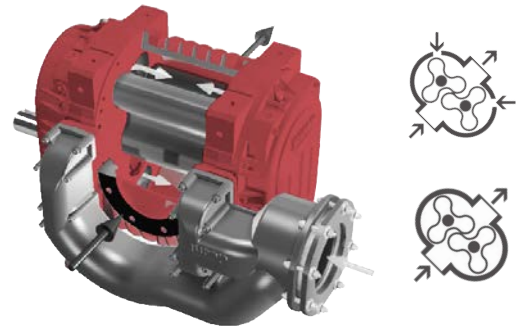

EFFICIENT FILTRATION SYSTEM

The vacuum unit is protected by class M polyester filters and safety cartridges, able to filter up to 1 micron dusts. Filter efficiency and vacuum cleaner performances are guaranteed by an automatic filter cleaning system which constantly cleans the filters.

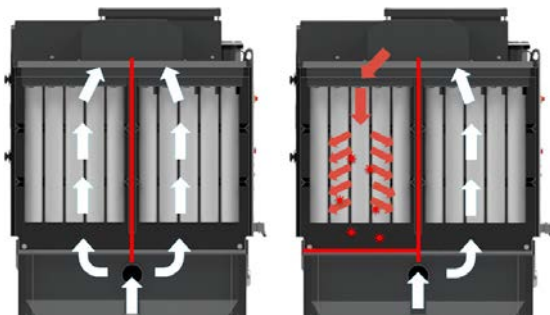

FILTER CLEANING IN ALTERNATING BACKWASH SYSTEM

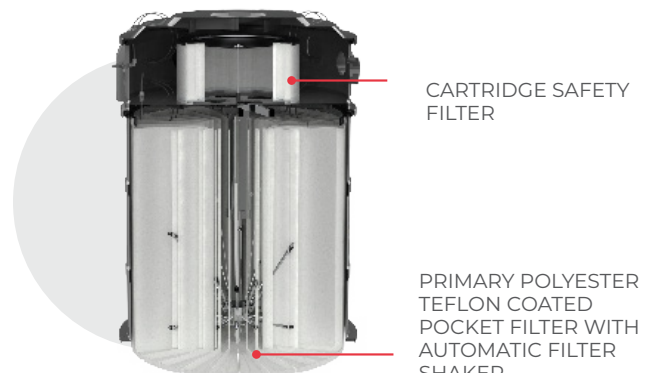

FILTER CLEANING SYSTEM FOR COMPACT RANGE

EASY HANDLING OF THE VACUUMED MATERIAL

The DHV vacuum cleaners are equipped with detachable and forked containers or with Big-Bag discharge hoppers for maximum ease and safety of use.



HIGH COLLECTION CANISTER EQUIPPED WITH FORKS INTAKES

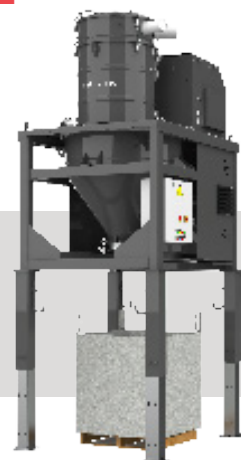

BIG BAG COLLECTION

CUSTOMIZED VACUUMING SOLUTIONS

Delfin engineers and manufactures centralized vacuum systems complete with vacuum unit, filter hoppers, preseparators and piping, that allow to vacuum material even from multiple points simultaneously.

A centralized vacuum system allows to:

- Improve the hygiene level and cleanliness of working environments.
- Collect materials, convey or dispose of them in an easy, safe and quick way.
- Increase safety level of working environments, thus reducing injury risks.
- Reduce the environmental impact of the company.

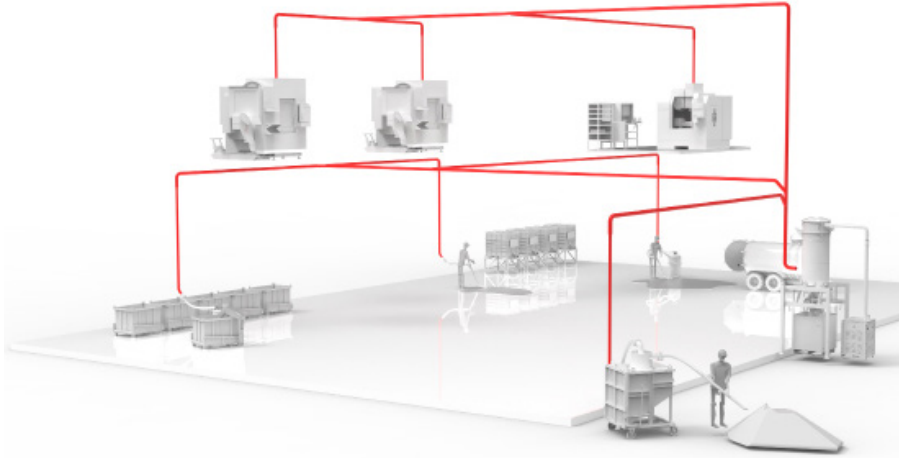

POWERFUL VACUUM UNITS

The vacuum unit is the heart of the centralized system and its power must be dimensioned considering the specific need of the customer. Delfin vacuum units are equipped with sound-proof cabin and cooling fan.

		CV 22AF	CV 22HV	CV 30AF	CV 30HV	CV 37AF	CV 37HV	CV 45AF	CV 45HV
Power	kW	22	22	30	30	37	37	45	45
Max Water lift		5.000	7.500	5.000	7.500	5.000	7.200	5.000	8.500
Air flow	m ³ /h	1.300	1.100	1.700	1.300	2.000	1.500	2.300	1.700



FILTER HOPPERS

In order to guarantee the maximum power for the vacuum unit it is necessary to protect the engines from dusts by means of filter hoppers. Delfin pre-separators are equipped with a cyclonic cover, equipped with filtering sleeves, and automatic alternating backwash.

FILTER HOPPER WITH LADDER AND PLATFORM

FILTER HOPPER
Ø780 LT500



FILTER HOPPER
Ø1200 LT1000

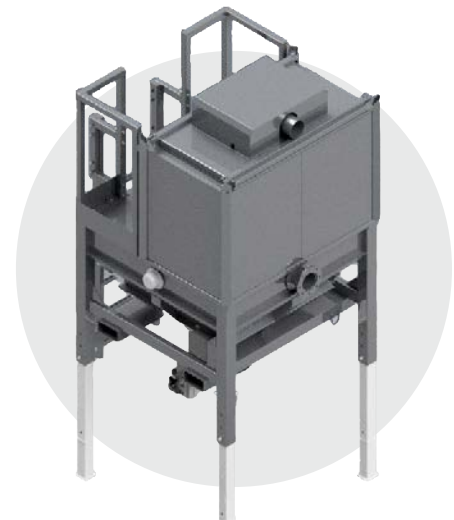

		FILTER HOP- PER 500LT	FILTER HOP- PER 1000LT	FILTER HOP- PER 1000LT
Capacity	lt	500	1000	1000
Main filter	cm ²	96.000	96.000	180.000

- Mobile separator with sleeves filters
- Backwash filter cleaning
- 1,000 litre hopper with inspection hatch
- Manual butterfly discharge Ø250
- Platform with ladder for filter maintenance
- Stability / Safety / Robustness
- Rotating level detector
- Filtering surface 180.000 cm²

PRESEPARATORS WITH CYCLONE

All pre-separators units are equipped with a cyclone and can be designed with different discharge systems.



EASY TO HANDLE BY MEANS OF
FORK LIFT INTAKES



AUTOMATIC
SNAP CLOSURE



CHASSIS WITH DIFFERENT
HEIGHTS AVAILABLE UPON RE-
QUEST



GUILLOTINE
DISCHARGE VALVE

DISCHARGE SYSTEM FOR ANY NEED

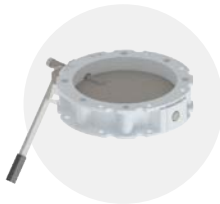

BUTTERFLY
VALVE



DOUBLE BUTTER-
FLY VALVE

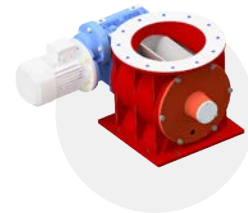

ROTOVALVE FOR
CONTINUOUS DISCHARGE

SAFETY EQUIPMENT

Every product can be equipped with additional safety systems, to satisfy any installation requirement.



EXPLOSION VENTS



EXPLOSION RELIEFE VALVES



ISOLATION FLAP VALVES



ATEX CERTIFICATION

STURDY AND LONG-LASTING COMPONENTS

Reinforced piping for the complete customization of the system.



PIPING



BENDS



BRANCH PIPES



REINFORCED
CUFFS

ERGONOMIC AND USER-FRIENDLY ACCESSORIES

Accessories engineered to simplify maintenance operations and vacuuming of large quantities of material.



SCRAPING NOZZLE
WITH WHEELS



VERTICAL ACCE-
SSORY WITH HANDLE



PROBE PIPE WITH
AIR FLUIDIFICATION



DOUBLE BEND AND
BRUSH FOR FLOOR
CLEANING



ABRASION-PROOF
HOSE PU SUPER HD

VACUUMING SOLUTIONS FOR HEAVY INDUSTRIES

In order to keep the highest production efficiency and security standards, cement plants, foundries, steelworks, incinerators and power plants require powerful and effective cleaning tools, able to deal with large quantities of material.

DHV Delfin industrial vacuums make it easy and safe to remove and move large quantities of dusty or solid material. Thanks to its features, the DHV range is the most suitable vacuuming solution to the needs of industries dealing with large quantities of dusts, wastes and residuals which constantly mine their production efficiency and safety.



CEMENT PLANTS AND LIME



MINES



POWER GENERATION
(COAL, BIOMASS, INCINERATORS)



FOUNDRIES



STEEL WORKS
(FORGING, LAMINATION, SANDBLASTING)



GLASS FACTORIES



SHIPYARDS



FERTILIZER PLANTS

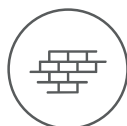

BRICK & TILES



REFINERIES

Delfin is an Italian company that started as a small family business and has evolved into a global specialist in industrial dust management. For over 40 years, Delfin has been developing innovative solutions for the vacuuming, filtration, and conveying of materials within industrial processes. The company combines entrepreneurial vision with strong managerial leadership, led by a team of young managers alongside the founding family. With more than 200 employees and a presence in over 80 countries, Delfin exports 80% of its production worldwide. Its goal is to transform dust from a problem into an opportunity.



Delfin Srl · Strada della Merla 49/A · 10036 Settimo T.se (To) Italy
Tel +39 011 800 55 00
delfin@delfinvacuums.it · delfinvacuums.com

REV 1.2026