

# DG VL 185 ACD

INDUSTRIAL VACUUM CLEANERS FOR HEAVY AND CONTINUOUS APPLICATIONS

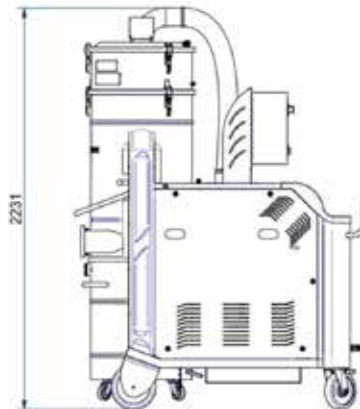

Filter category:



## FEATURES

Dust and solids

Industrial construction with high durability and easy maintenance, designed for forklift handling  
Complete painted steel construction

SELF CLEAN filter shaker cleaning system (with compressor included)

ATEX certified filter cleaning system

## TECHNICAL DATA

 OPTIONAL

		ACDDGVL185-001
Use Zone		Non-classified environment
Marking		II 1/-D Ex h IIIC T135°C (Internal) From/-
Ex Category		1/- D (ACD)
Voltage	V	400
Power	kW	21.3
Frequency	Hz	50
Current draw	A	38.3
Suction inlet diameter	mm	120
Tank capacity	L.	160
Noise level	dB(A)	82
Dimensions	cm	170x74x240h
Weight	kg	450
Electrical protection	IP	65
Maximum vacuum	mmH2O	4000
Continuous waterlift	mmH2O	3200
Maximum air flow	m <sup>3</sup> /h	1370
Motor Type		Three-phase Turbine
Primary filter		Star
Primary filter load	m <sup>3</sup> (m <sup>2</sup> /h)	192
Primary filter surface area	cm <sup>2</sup>	70000
Primary filter diameter	mm	560
Primary filter media		Polyester
Filter class (IEC 60335-2-69) primary filter		ANT M
Filter cleaning system		SELF CLEAN
Absolute HEPA Filter		Included
Filter area of the absolute filter	cm <sup>2</sup>	103500



MACHINE CODE	DESCRIPTION
ACDDGVL185-001	DG VL 185 ACD 160L DT DS H

All data mentioned in this document may change without notice. All data contained in this document is subject to change without notice.

COPYRIGHT 2026 DELFIN S.R.L. ALL RIGHTS RESERVED  
COPYRIGHT 2026 DELFIN S.R.L. ALL RIGHTS RESERVED

**DELFIN**  
FOR A DUST-FREE WORLD

www.delfinvacuums.com  
delfin@delfinvacuums.it