

DG VL 75 ACD

INDUSTRIAL VACUUM CLEANERS FOR HEAVY AND CONTINUOUS APPLICATIONS

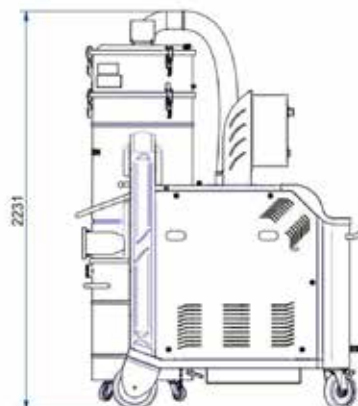

Filter category:



FEATURES

Dust / Solids

Industrial construction with high durability and easy maintenance, designed for forklift handling
Complete painted steel construction

SELF CLEAN filter shaker cleaning system (with compressor included)

ATEX certified filter cleaning system

TECHNICAL DATA

 OPTIONAL

		ACDDGVL75-001
Use Zone		Non-classified environment
Marking		II 1/-D Ex h IIIC T135°C (Internal) From/-
Ex Category		1/- D (ACD)
Voltage	V	400
Power	kW	7.5
Frequency	Hz	50
Current draw	A	15
Suction inlet diameter	mm	120
Tank capacity	L.	160
Noise level	dB(A)	74
Dimensions	cm	170x74x200h
Weight	kg	360
Electrical protection	IP	55
Maximum vacuum	mmH2O	4500
Continuous waterlift	mmH2O	3100
Maximum air flow	m ³ /h	750
Motor Type		Three-phase Turbine
Primary filter		Star
Primary filter load	m ³ (m ² /h)	107
Primary filter surface area	cm ²	70000
Primary filter diameter	mm	560
Primary filter media		Polyester
Filter class (IEC 60335-2-69) primary filter		ANT M
Filter cleaning system		SELF CLEAN
Absolute HEPA Filter		Included
Filter area of the absolute filter	cm ²	52000



MACHINE CODE	DESCRIPTION
ACDDGVL75-001	DG VL 75 ACD 160L DT DS H

All data mentioned in this document may change without notice. All data contained in this document is subject to change without notice.

DELFIN
FOR A DUST-FREE WORLD

www.delfinvacuums.com
delfin@delfinvacuums.it