

AF 20 FIXE

ARC WELDING FLUX RECOVERY UNIT FOR SUBMERGED ARC WELDING SYSTEMS

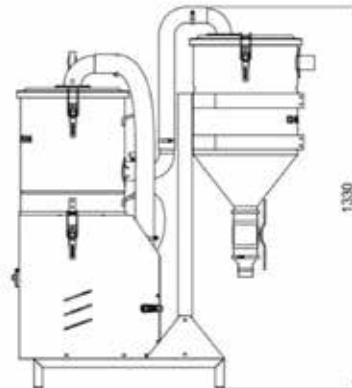
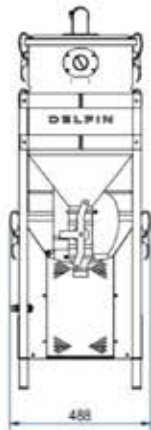

Filter category:

FEATURES

Arc welding flux recovery unit

Extreme modularity for optimal adaptation to the welding machine

All data mentioned in this document may change without notice. All data contained in this document is subject to change without notice.

DELFIN
FOR A DUST-FREE WORLD
www.delfinvacuums.com
delfin@delfinvacuums.it

COPYRIGHT 2026 DELFIN S.R.L. ALL RIGHTS RESERVED
COPYRIGHT 2026 DELFIN S.R.L. ALL RIGHTS RESERVED

TECHNICAL DATA

 OPTIONAL

		AF.FIXE20MAN-001
Voltage	V	400
Power	kW	2.5
Frequency	Hz	50
Current draw	A	5.0
Suction inlet diameter	mm	50
Tank capacity	L.	50
Noise level	dB(A)	70
Dimensions	cm	120x52x140 h
Hopper Diameter		360
Maximum vacuum	mmH2O	3000
Continuous waterlift	mmH2O	2200
Maximum air flow	m ³ /h	318
Motor Type		Three-phase Turbine



MACHINE CODE	DESCRIPTION
AF.FIXE20MAN-001	AF/FIXE 20 FLOW SUCTION UNIT WITH HOPPER

All data mentioned in this document may change without notice. All data contained in this document is subject to change without notice.

DELFIN
FOR A DUST-FREE WORLD

www.delfinvacuums.com
delfin@delfinvacuums.it