

C600 T150 SE

THREE-PHASE VACUUM CLEANERS FOR CONTINUOUS USE IN THE MANAGEMENT OF LARGE VOLUMES OF MATERIAL

Filter category:



FEATURES

Large quantities of material

Industrial construction with high durability and easy maintenance, with forklift pockets
Complete painted steel construction

Manual filter cleaning system

Front material discharge, vacuum unit easily detachable from the container and filter

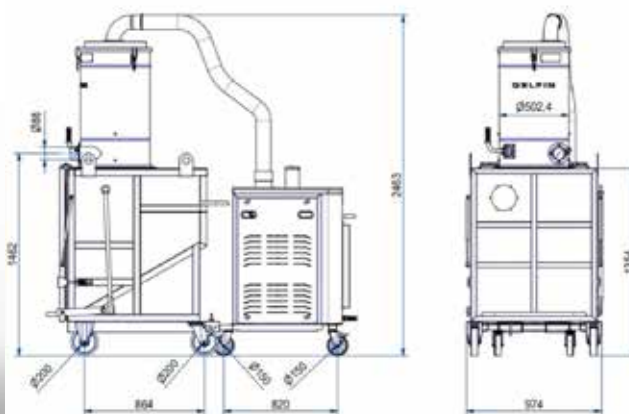

COPYRIGHT 2026 DELFIN S.R.L. ALL RIGHTS RESERVED
COPYRIGHT 2026 DELFIN S.R.L. ALL RIGHTS RESERVED

TECHNICAL DATA

 OPTIONAL

		C600T150SE-001
Voltage	V	400
Power	kW	15
Frequency	Hz	50
Current draw	A	30.7
Suction inlet diameter	mm	80
Tank capacity	L.	600
Noise level	dB(A)	78
Dimensions	cm	230x1000x250h
Weight	kg	700
Maximum vacuum	mmH2O	6000
Continuous waterlift	mmH2O	5300
Maximum air flow	m ³ /h	720
Motor Type		Three-phase Turbine
Primary filter		Star
Primary filter load	m ³ (m ² /h)	147
Primary filter surface area	cm ²	49000
Primary filter media		Polyester
Filter class (IEC 60335-2-69) primary filter		ANT M
Filter cleaning system		Manual
Discharge system		Front discharge



MACHINE CODE	DESCRIPTION
C600T150SE-001	VACUUM SEPARATOR/SUCTION BUCKET 600L 17.3kW

All data mentioned in this document may change without notice. All data contained in this document is subject to change without notice.

COPYRIGHT 2026 DELFIN S.R.L. ALL RIGHTS RESERVED
COPYRIGHT 2026 DELFIN S.R.L. ALL RIGHTS RESERVED

DELFIN
FOR A DUST-FREE WORLD

www.delfinvacuums.com
delfin@delfinvacuums.it