

CANISTER

INTEGRATED SOLUTION FOR DUST

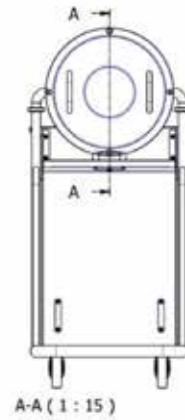
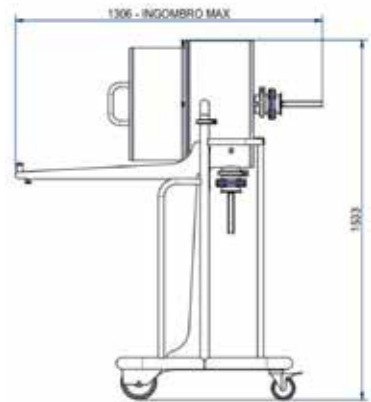

Filter category:

FEATURES

AISI304 mobile unit with H14 BAG-OUT (BIBO) filter

Filter surface 10m²

Total safety for the operator during maintenance and high efficiency during operation

The canister unit must be used with the cyclone pre-separator or extraction system

All data mentioned in this document may change without notice. All data contained in this document is subject to change without notice.

DELFIN
FOR A DUST-FREE WORLD
www.delfinvacuums.com
delfin@delfinvacuums.it

COPYRIGHT 2026 DELFIN S.R.L. ALL RIGHTS RESERVED
COPYRIGHT 2026 DELFIN S.R.L. ALL RIGHTS RESERVED

TECHNICAL DATA

 OPTIONAL

		CST.DC-001
Suction inlet diameter	mm	3"
Dimensions	cm	70x75x155h
Weight	kg	60
Maximum air flow	m ³ /h	1000
Primary filter surface area	cm ²	100000
Filter class (IEC 60335-2-69) primary filter		H14 with 99.995% efficiency according to the MPPS method
Filtration efficiency		H14 with 99.995% efficiency at 0.18µm



MACHINE CODE	DESCRIPTION
CST.DC-001	Integrated system with canister

All data mentioned in this document may change without notice. All data contained in this document is subject to change without notice.

DELFIN
FOR A DUST-FREE WORLD

www.delfinvacuums.com
delfin@delfinvacuums.it

COPYRIGHT 2026 DELFIN S.R.L. ALL RIGHTS RESERVED
COPYRIGHT 2026 DELFIN S.R.L. ALL RIGHTS RESERVED