

# CV CABIN CENTRAL VACUUM

FIXED VACUUM UNIT 30 kW HIGH CAPACITY WITH SOUNDPRO-  
OF CABIN

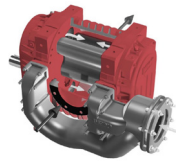

Filter category:



## FEATURES

High-performance stationary vacuum unit with 3-lobe rotary pump

Soundproofed, forced-ventilation cabinet with large inspection hatches, safety filter cartridge, and silencer.

To be used exclusively in combination with a preseparators with filter.

The electrical panel must be ordered separately and includes a Schneider Zelio PLC, hour meter, vacuum gauge, and pump and motor temperature sensors. Other options for the electrical panel, to be added separately

All data mentioned in this document is subject to change without notice. All data contained in this document is subject to change without notice.

**DELFIN**  
FOR A DUST-FREE WORLD  
[www.delfinvacuums.com](http://www.delfinvacuums.com)  
[delfin@delfinvacuums.it](mailto:delfin@delfinvacuums.it)

COPYRIGHT 2026 DELFIN S.R.L. ALL RIGHTS RESERVED  
COPYRIGHT 2026 DELFIN S.R.L. ALL RIGHTS RESERVED

## TECHNICAL DATA

		CV30AFC-001
Voltage	V	400
Power	kW	30
Frequency	Hz	50
Suction inlet diameter	mm	140
Noise level	dB(A)	80
Dimensions	cm	114x124x147h
Weight	kg	710
Electrical protection	IP	55
Maximum air flow	m <sup>3</sup> /h	1700
Secondary filter		CARTRIDGE
Secondary filter surface area	cm <sup>2</sup>	70000
secondary filter diameter	mm	270
Secondary filter media		Polyester
Secondary filter class		M
safety filter		CARTRIDGE
Filter surface area of safety filter	cm <sup>2</sup>	70000
Safety filter diameter	mm	270
Filter media - safety filter		POLYESTER
Filter class - safety filter (IEC 60335-2-69)		M

## OPTIONAL

EP - 30 kW	Electrical Panel 30kW
EP.0104.0000	Neoprene power cable H07RNF 4G10 (22 kW)
EP.0698.0000	Neoprene power cable H07RNF 4G16 (30/37 kW)
EP.0971.0000	Neoprene power cable H07RNF 4G25 (45 kW)
EP.0667.0000	Plug 63A 3P+T IP67
EP.0711.0000	
EP.0689.0000	Plug 125A 3P+T IP67
EP.1547.0000	Plug 125A 4P+T IP67
FI.0467.0000	Safety filter D290 H455 H13

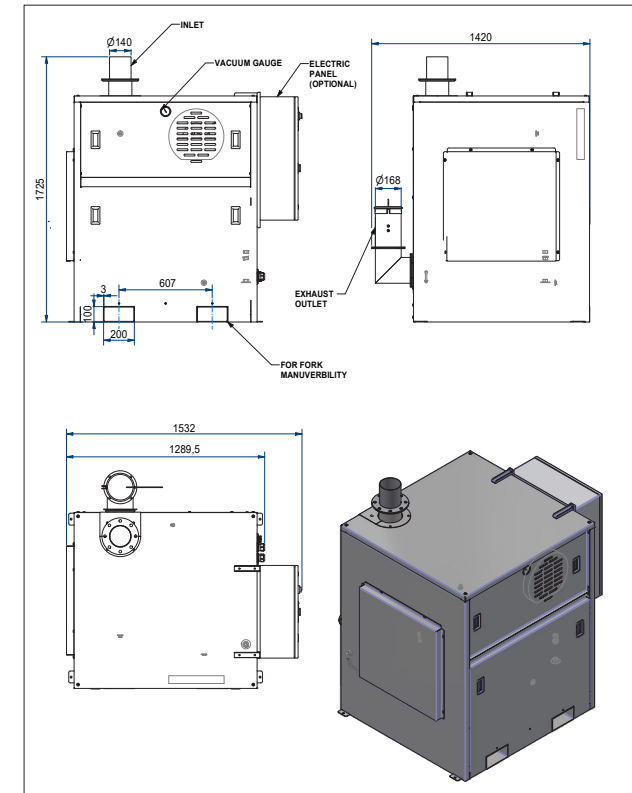

COPYRIGHT 2026 DELFIN S.R.L. ALL RIGHTS RESERVED  
COPYRIGHT 2026 DELFIN S.R.L. ALL RIGHTS RESERVED

MACHINE CODE	DESCRIPTION
CV30AFC-001	CV 30 AF with soundproof enclosure Without Electrical panel

All data mentioned in this document is subject to change without notice. All data contained in this document is subject to change without notice.

**DELFIN**  
FOR A DUST-FREE WORLD

www.delfinvacuums.com  
delfin@delfinvacuums.it