

# DG VL 125

INDUSTRIAL VACUUM CLEANERS FOR SUCTION OF DUST AND PACKED SOLIDS

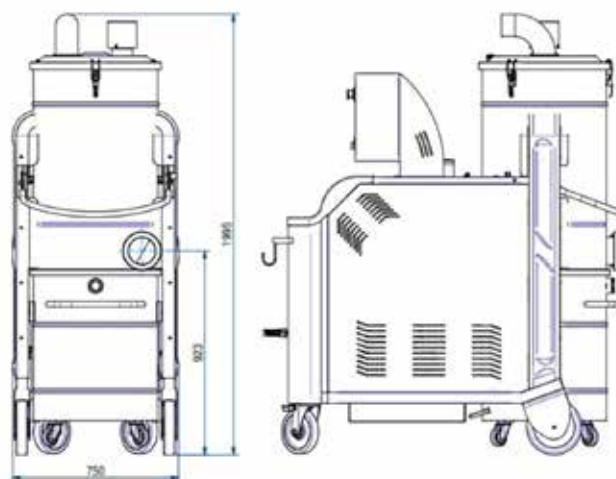

Filter category:



## FEATURES

Dust and solids

Industrial construction with high durability and easy maintenance, with forklift pockets  
Complete painted steel construction

SELF CLEAN filter shaker cleaning system (with compressor included)

Continuous service, no maintenance required

All data mentioned in this document may change without notice. All data contained in this document is subject to change without notice.

**DELFIN**  
FOR A DUST-FREE WORLD  
[www.delfinvacuums.com](http://www.delfinvacuums.com)  
[delfin@delfinvacuums.it](mailto:delfin@delfinvacuums.it)

COPYRIGHT 2026 DELFIN S.R.L. ALL RIGHTS RESERVED  
COPYRIGHT 2026 DELFIN S.R.L. ALL RIGHTS RESERVED

## TECHNICAL DATA

		DGVL125-001
Voltage	V	400
Power	kW	12.6
Frequency	Hz	50
Current draw	A	23.3
Suction inlet diameter	mm	120
Tank capacity	L.	160
Noise level	dB(A)	78
Dimensions	cm	170x75x200h
Weight	kg	430
Electrical protection	IP	65
Maximum vacuum		4000
Continuous waterlift		2900
Maximum air flow		1050
Motor Type		Three-phase Turbine
Primary filter		Star
Primary filter load	m <sup>3</sup> (m <sup>2</sup> /h)	157
Primary filter surface area	cm <sup>2</sup>	70000
Primary filter diameter	mm	560
Primary filter media		Polyester
Filter class (IEC 60335-2-69) primary filter		ANT M
Filter cleaning system		SELF CLEAN
Absolute HEPA Filter		Optional
Filter area of the absolute filter	cm <sup>2</sup>	103500
Absolute filter class (EN 1822-5)		H14 with 99.995% efficiency according to the MPPS method
Pressure relief valve		Included
Compressor		Included

## OPTIONAL

Code	Description
H	Additional H14 absolute filter
M PTFE	Class M filter with PTFE coating
TIMED	Automatic, timed filter shaking
X	AISI 304 stainless steel container
XX	Steel container and filter chamber in AISI 304 stainless steel
MT	Earth Grounding
LOC/REM (ATEX+25%)	Remote control (with 24V electric panel if not present) +25% ATEX
HARDOX	Reinforced plate for filter chamber
FLOOR-MOUNTED	Fixed floor frame



COPYRIGHT 2026 DELFIN S.R.L. ALL RIGHTS RESERVED  
COPYRIGHT 2026 DELFIN S.R.L. ALL RIGHTS RESERVED

MACHINE CODE	DESCRIPTION
DGVL125-001	DG VL 125 - Compressor included / Compressor included 160L DT DS

All data mentioned in this document may change without notice. All data contained in this document is subject to change without notice.

**DELFIN**  
FOR A DUST-FREE WORLD

www.delfinvacuums.com  
delfin@delfinvacuums.it