

# DG VL 185

INDUSTRIAL VACUUM CLEANERS FOR SUCTION OF DUST AND PACKED SOLIDS

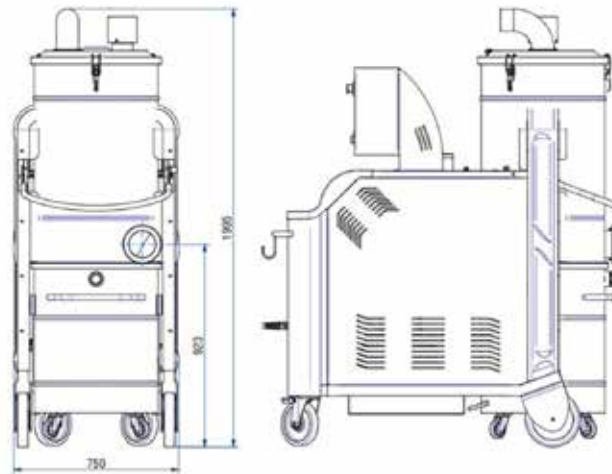

Filter category:



## FEATURES

Dust and solids

Industrial construction with high durability and easy maintenance, with forklift pockets

Complete painted steel construction

SELF CLEAN filter shaker cleaning system (with compressor included)

Continuous service, no maintenance required

All data mentioned in this document may change without notice. All data contained in this document is subject to change without notice.

**DELFIN**  
FOR A DUST-FREE WORLD  
[www.delfinvacuums.com](http://www.delfinvacuums.com)  
[delfin@delfinvacuums.it](mailto:delfin@delfinvacuums.it)

COPYRIGHT 2026 DELFIN S.R.L. ALL RIGHTS RESERVED  
COPYRIGHT 2026 DELFIN S.R.L. ALL RIGHTS RESERVED

## TECHNICAL DATA

		DGVL185-001
Voltage	V	400
Power	kW	21.3
Frequency	Hz	50
Current draw	A	38.3
Suction inlet diameter	mm	120
Tank capacity	L	160
Noise level	dB(A)	82
Dimensions	cm	170x75x200h
Weight	kg	450
Electrical protection	IP	65
Maximum vacuum	mmH2O	4000
Continuous waterlift	mmH2O	3200
Maximum air flow	m <sup>3</sup> /h	1350
Motor Type		Three-phase Turbine
Primary filter		Star
Primary filter load	m <sup>3</sup> (m <sup>2</sup> /h)	192
Primary filter surface area	cm <sup>2</sup>	70000
Primary filter diameter	mm	560
Primary filter media		Polyester
Filter class (IEC 60335-2-69) primary filter		ANT M
Filter cleaning system		SELF CLEAN
Absolute HEPA Filter		Optional
Filter area of the absolute filter	cm <sup>2</sup>	103500
Absolute filter class (EN 1822-5)		H14 with 99.995% efficiency according to the MPPS method
Pressure relief valve		Included
Compressor		Included

## OPTIONAL

Code	Description
<b>H</b>	Additional H14 absolute filter
<b>M PTFE</b>	Class M filter with PTFE coating
<b>TIMED</b>	Automatic, timed filter shaking
<b>X</b>	AISI 304 stainless steel container
<b>XX</b>	Steel container and filter chamber in AISI 304 stainless steel
<b>MT</b>	Earth Grounding
<b>LOC/REM (ATEX+25%)</b>	Remote control (with 24V electric panel if not present) +25% ATEX
<b>HARDOX</b>	Reinforced plate for filter chamber
<b>FLOOR-MOUNTED</b>	Fixed floor frame



COPYRIGHT 2026 DELFIN S.R.L. ALL RIGHTS RESERVED

MACHINE CODE	DESCRIPTION
DGVL185-001	DG VL 185 - Compressor Included 160L DT DS

All data mentioned in this document may change without notice. All data contained in this document is subject to change without notice.

**DELFIN**  
FOR A DUST-FREE WORLD

www.delfinvacuums.com  
delfin@delfinvacuums.it