

# DHV TANK

INDUSTRIAL VACUUM CLEANER MOBILE HIGH CAPACITY 45 kW  
WITH 800L TANK



Filter category:



## FEATURES

High-performance mobile vacuum unit for heavy industry, movable with a forklift

Equipped with a 3-lobe rotary pump PTFE bag filter with automatic alternating backwash cleaning

800-liter removable container, unloadable from the bottom via a hatch On-board Compressor for continuous filter cleaning

Electrical panel with Schneider Zelio PLC, hour meter, filter status pressure switch, pump temperature sensor, motor PTC, level sensor, Remote control

All data mentioned in this document is subject to change without notice. All data contained in this document is subject to change without notice.

**D E L F I N**  
FOR A DUST-FREE WORLD  
[www.delfinvacuums.com](http://www.delfinvacuums.com)  
[delfin@delfinvacuums.it](mailto:delfin@delfinvacuums.it)

COPYRIGHT 2026 DELFIN S.R.L. ALL RIGHTS RESERVED  
COPYRIGHT 2026 DELFIN S.R.L. ALL RIGHTS RESERVED

## TECHNICAL DATA

		DHV45AFT-001
Voltage	V	400
Power	kW	45
Frequency	Hz	50
Suction inlet diameter	mm	140
Tank capacity	L.	800
Noise level	dB(A)	80
Dimensions	cm	168x160x291h
Weight	kg	2550
Electrical protection	IP	55
Maximum air flow	m <sup>3</sup> /h	2300
Primary filter		30 sleeves
Primary filter load	m <sup>3</sup> (m <sup>2</sup> /h)	143
Primary filter surface area	cm <sup>2</sup>	160000
Primary filter media		Polyester
Filter class (IEC 60335-2-69) primary filter		ANT M PTFE
safety filter		CARTRIDGE
Filter surface area of safety filter	cm <sup>2</sup>	70000
Safety filter diameter	mm	270
Filter media - safety filter		POLYESTER
Filter class - safety filter (IEC 60335-2-69)		M

## OPTIONAL

EP.0971.0000	Neoprene power cable H07RNF 4G25 (45 kW)
EP.0689.0000	Plug 125A 3P+T IP67
EP.1547.0000	Plug 125A 4P+T IP67
FI.0467.0000	Safety filter D290 H455 H13
ST.0565.7011Z	Big Bag discharge frame and continuous discharge h 1,000 / 1,500

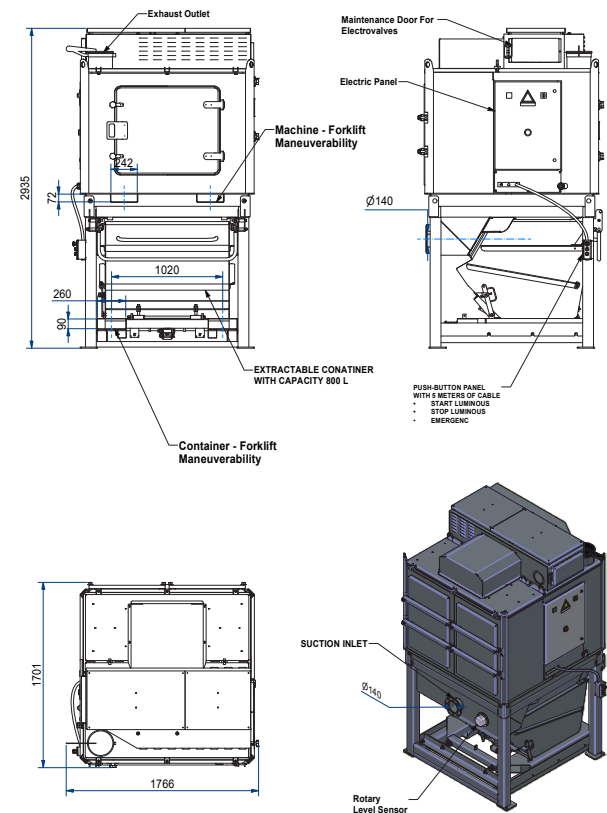

COPYRIGHT 2026 DELFIN S.R.L. ALL RIGHTS RESERVED  
COPYRIGHT 2026 DELFIN S.R.L. ALL RIGHTS RESERVED

MACHINE CODE	DESCRIPTION
DHV45AFT-001	DHV 45 Airflow with tank / High flow with tank

All data mentioned in this document is subject to change without notice. All data contained in this document is subject to change without notice.

**DELFIN**  
FOR A DUST-FREE WORLD

www.delfinvacuums.com  
delfin@delfinvacuums.it