

MTL 202 ACD LP

INDUSTRIAL VACUUM CLEANER ACD FOR NON-CONTINUOUS APPLICATIONS IN NON-ATEX ZONES ENDLESS BAG VERSION

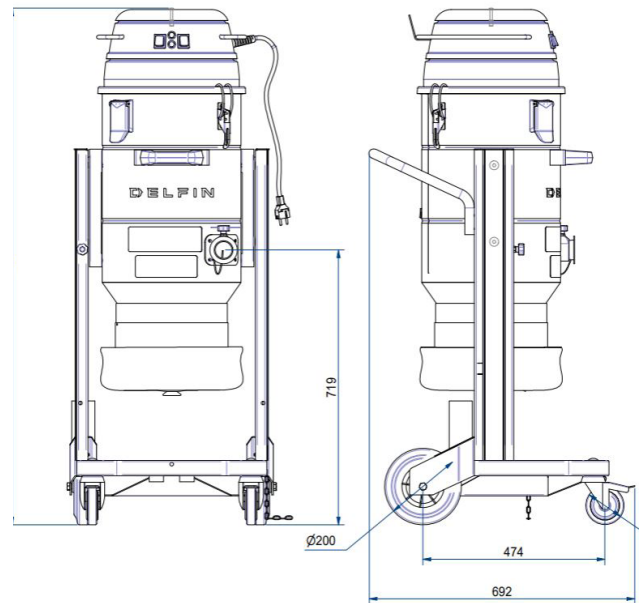

Filter category:



FEATURES

Dust and solids

Compact and mobile

Endless Bag

Class M antistatic, integrated Dustop filter cleaning system

Certified Ex tb Dust Tight IP64 head, ATEX-tested accessories and non-metallic parts

All data mentioned in this document may change without notice. All data contained in this document is subject to change without notice.

DELFIN
FOR A DUST-FREE WORLD
www.delfinvacuums.com
delfin@delfinvacuums.it

COPYRIGHT 2026 DELFIN S.R.L. ALL RIGHTS RESERVED
COPYRIGHT 2026 DELFIN S.R.L. ALL RIGHTS RESERVED

TECHNICAL DATA

 OPTIONAL

		MTL202ACD-001
Use Zone		Non-classified environment
Marking		II 1/-D Ex h IIIC T80°C (Internal) Da/-
Ex Category		1/- D (ACD)
Voltage	V	230
Power	kW	2.2
Frequency	Hz	50/60
Current draw	A	10
Suction inlet diameter	mm	50
Tank capacity	L.	20
Noise level	dB(A)	74
Dimensions	cm	51x57x104h
Weight	kg	35
Maximum vacuum	mmH2O	2500
Continuous waterlift	mmH2O	2500
Maximum air flow	m ³ /h	360
Motor Type		Single-phase Bypass
Primary filter		Cartridge
Primary filter load	m ³ (m ² /h)	120
Primary filter surface area	cm ²	30000
Primary filter diameter	mm	360
Primary filter media		Polyester
Filter class (IEC 60335-2-69) primary filter		ANT M
Filter cleaning system		Dustop
Absolute HEPA Filter		Standard
Filter area of the absolute filter	cm ²	20500
Absolute filter class (EN 1822-5)		H14 with 99.995% efficiency according to the MPPS method



COPYRIGHT 2026 DELFIN S.R.L. ALL RIGHTS RESERVED
COPYRIGHT 2026 DELFIN S.R.L. ALL RIGHTS RESERVED

MACHINE CODE	DESCRIPTION
MTL202LPACD-001	MTL 202 LP ACD EX 1/-D 2BP 20M DUSTOP H KIT 40

All data mentioned in this document may change without notice. All data contained in this document is subject to change without notice.

DELFIN
FOR A DUST-FREE WORLD

www.delfinvacuums.com
delfin@delfinvacuums.it