

MTL452 ACD

ACD CERTIFIED ANTI-EXPLOSION VACUUM CLEANER

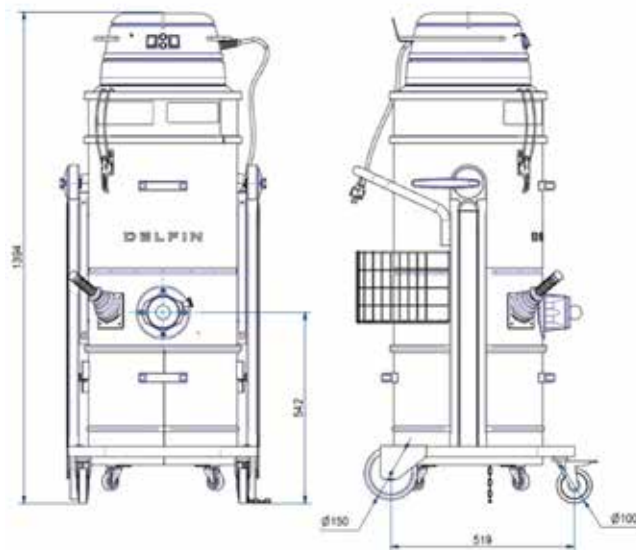

Filter category:



FEATURES

Dust and solids / suitable for work in zone 21 (cat 2D)

Compact and mobile

AISI 304 stainless steel tank; Filter: polyester, class M anti-static; integrated manual cleaning system

Certified Ex tb Dust Tight IP64 head, ATEX-tested accessories and non-metallic parts

Compliance with EN IEC 62784:2018 for Zone 22

All data mentioned in this document may change without notice. All data contained in this document is subject to change without notice.

DELFIN
FOR A DUST-FREE WORLD
www.delfinvacuums.com
delfin@delfinvacuums.it

COPYRIGHT 2026 DELFIN S.R.L. ALL RIGHTS RESERVED
COPYRIGHT 2026 DELFIN S.R.L. ALL RIGHTS RESERVED

TECHNICAL DATA

 OPTIONAL

		MTL452ACD-001
Use Zone		Non-classified environment
Marking		II 1/-D Ex h IIIC T80°C (Internal) Da/-
Ex Category		1/- D (ACD)
Voltage	V	230
Power	kW	2.2
Frequency	Hz	50/60
Current draw	A	10
Suction inlet diameter	mm	80
Tank capacity	L.	45
Noise level	dB(A)	74
Dimensions	cm	58x70x140h
Weight	kg	56
Maximum vacuum	mmH2O	2500
Continuous waterlift	mmH2O	2500
Maximum air flow	m ³ /h	360
Motor Type		Single-phase Bypass
Primary filter		Star
Primary filter load	m ³ (m ² /h)	180
Primary filter surface area	cm ²	20500
Primary filter diameter	mm	420
Primary filter media		Polyester
Filter class (IEC 60335-2-69) primary filter		ANT M
Filter cleaning system		Manual
Absolute HEPA Filter		Standard
Filter area of the absolute filter	cm ²	20500
Absolute filter class (EN 1822-5)		H14 with 99.995% efficiency according to the MPPS method



MACHINE CODE	DESCRIPTION
MTL452ACD-001	MTL452 ACD EX 1/- D 2BP 45L DT DS X H KIT 40

All data mentioned in this document may change without notice. All data contained in this document is subject to change without notice.

COPYRIGHT 2026 DELFIN S.R.L. ALL RIGHTS RESERVED
COPYRIGHT 2026 DELFIN S.R.L. ALL RIGHTS RESERVED

DELFIN
FOR A DUST-FREE WORLD

www.delfinvacuums.com
delfin@delfinvacuums.it