

SEP.DLF-0019

INDUSTRIAL VACUUM CLEANER FOR HAZARDOUS DUST WITH INTEGRATED CYCLONE



Filter category:

FEATURES

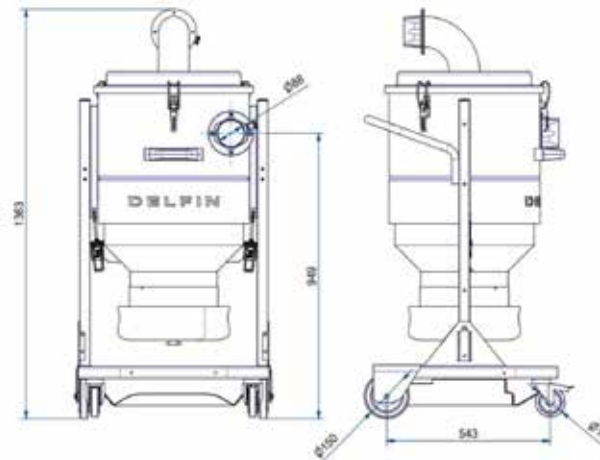

All data mentioned in this document may change without notice. All data contained in this document is subject to change without notice.

DELFIN
FOR A DUST-FREE WORLD
www.delfinvacuums.com
delfin@delfinvacuums.it

COPYRIGHT 2026 DELFIN S.R.L. ALL RIGHTS RESERVED
COPYRIGHT 2026 DELFIN S.R.L. ALL RIGHTS RESERVED

TECHNICAL DATA

 OPTIONAL

		SEP.DLF-0019
Chamber with cyclone	mm	500
Suction inlet diameter	mm	80
Dimensions	cm	70x66x140
Weight	kg	68



MACHINE CODE	DESCRIPTION
SEP.DLF-0019	Endless bag preseparator Ø500

All data mentioned in this document may change without notice. All data contained in this document is subject to change without notice.

DELFIN
FOR A DUST-FREE WORLD

www.delfinvacuums.com
delfin@delfinvacuums.it