

SILOS 1000

FIXED PRESEPARATOR WITH 1000L ø1200 CYCLONE AND BUTTERFLY VALVE



Filter category:

FEATURES

High-efficiency cyclonic Preseparators with male spherical connections

Available in two versions: mobile with bottom discharge via a door, fixed with a conical container and a 250 mm butterfly valve

All data mentioned in this document is subject to change without notice. All data contained in this document is subject to change without notice.

DELFIN
FOR A DUST-FREE WORLD
www.delfinvacuums.com
delfin@delfinvacuums.it

COPYRIGHT 2026 DELFIN S.R.L. ALL RIGHTS RESERVED
COPYRIGHT 2026 DELFIN S.R.L. ALL RIGHTS RESERVED

TECHNICAL DATA

		SEP.DLF-0085
Suction inlet diameter	mm	127
Tank capacity	L.	1000
Dimensions	cm	144x144x246h
Weight	kg	270
Discharge system		Manual butterfly valve ϕ 250

OPTIONAL

ST.1762.7011Z	Adjustable frame for big-bag discharge hopper ϕ 780
ST.0618.7011Z	Adjustable frame for big-bag discharge hopper ϕ 1200

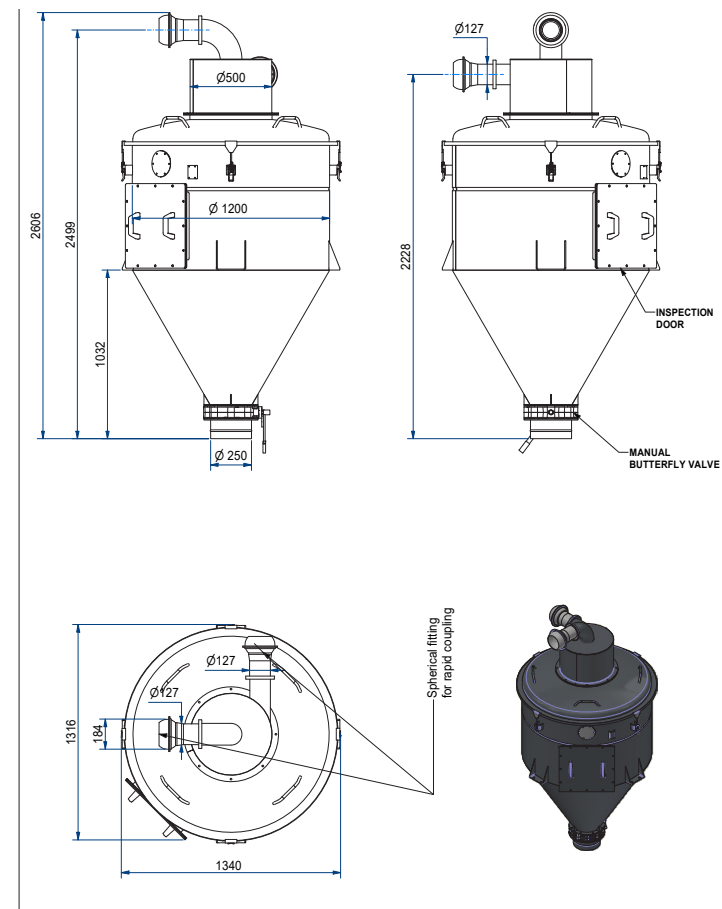

COPYRIGHT 2026 DELFIN S.R.L. ALL RIGHTS RESERVED
COPYRIGHT 2026 DELFIN S.R.L. ALL RIGHTS RESERVED

MACHINE CODE	DESCRIPTION
SEP.DLF-0085	Silo with cyclone 1MC ϕ 1200

All data mentioned in this document is subject to change without notice. All data contained in this document is subject to change without notice.

DELFIN
FOR A DUST-FREE WORLD

www.delfinvacuums.com
delfin@delfinvacuums.it