

FILTER HOPPER ROUND FILTER PRESEPARATORS

ROUND FILTERING PRESEPARATOR \varnothing 780 500L WITH PTFE SLEEVES



Filter category:



FEATURES

Preseparators with filter sleeves in PTFE and alternating automatic reverse air cleaning

Conical collection hopper with manual butterfly valve D.250 mm and inspection door

Electrical junction box for connection to vacuum unit

Require connection to an external compressed air network

All data mentioned in this document is subject to change without notice. All data contained in this document is subject to change without notice.

DELFIN
FOR A DUST-FREE WORLD
www.delfinvacuums.com
delfin@delfinvacuums.it

COPYRIGHT 2026 DELFIN S.R.L. ALL RIGHTS RESERVED
COPYRIGHT 2026 DELFIN S.R.L. ALL RIGHTS RESERVED

TECHNICAL DATA

		SEP.DLF-0087
Suction inlet diameter	mm	140
Tank capacity	L.	500
Dimensions	cm	102x102x295h
Weight	kg	280
Primary filter		16 sleeves
Primary filter surface area	cm ²	96000
Primary filter media		Polyester
Filter class (IEC 60335-2-69) primary filter		ANT M PTFE
Filter cleaning system		Alternating automatic in backwashing

OPTIONAL

ST.1762.7011Z	Adjustable frame for big-bag discharge hopper Ø780
ST.0618.7011Z	Adjustable frame for big-bag discharge hopper Ø1200

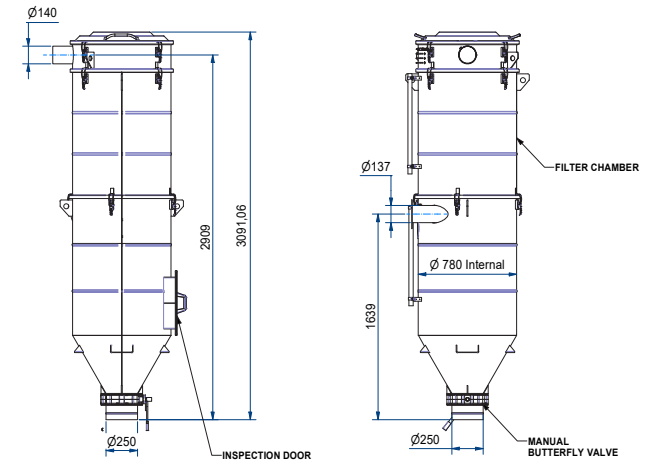

B-B (1:30)

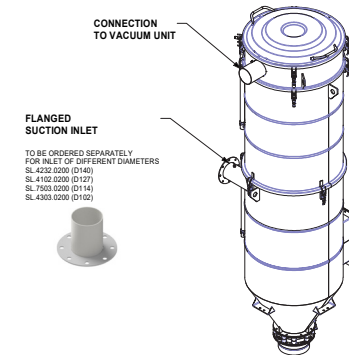
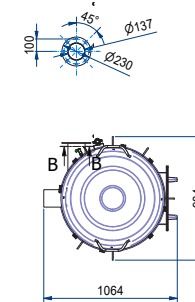

COPYRIGHT 2026 DELFIN S.R.L. ALL RIGHTS RESERVED
COPYRIGHT 2026 DELFIN S.R.L. ALL RIGHTS RESERVED

MACHINE CODE	DESCRIPTION
SEP.DLF-0087	Filter separator Ø780 8.5m ² 500L

All data mentioned in this document is subject to change without notice. All data contained in this document is subject to change without notice.

DELFIN
FOR A DUST-FREE WORLD

www.delfinvacuums.com
delfin@delfinvacuums.it