

FILTER HOPPER ROUND FILTER PRESEPARATORS

ROUND FILTERING PRESEPARATOR Ø1200 1000L WITH 30 PTFE SLEEVES



Filter category:



FEATURES

Preseparators with filter sleeves in PTFE and alternating automatic reverse air cleaning

Conical collection hopper with manual butterfly valve D.250 mm and inspection door

Electrical junction box for connection to vacuum unit

Require connection to an external compressed air network

All data mentioned in this document is subject to change without notice. All data contained in this document is subject to change without notice.

DELFIN
FOR A DUST-FREE WORLD
www.delfinvacuums.com
delfin@delfinvacuums.it

COPYRIGHT 2026 DELFIN S.R.L. ALL RIGHTS RESERVED
COPYRIGHT 2026 DELFIN S.R.L. ALL RIGHTS RESERVED

TECHNICAL DATA

		SEP.DLF-0089
Suction inlet diameter	mm	140
Tank capacity	L.	1000
Dimensions	cm	144x144x316h
Weight	kg	540
Primary filter		30 sleeves
Primary filter surface area	cm ²	180000
Primary filter media		Polyester
Filter class (IEC 60335-2-69) primary filter		ANT M PTFE
Filter cleaning system		Alternating automatic in backwashing

OPTIONAL

ST.1762.7011Z	Adjustable frame for big-bag discharge hopper Ø780
ST.0618.7011Z	Adjustable frame for big-bag discharge hopper Ø1200

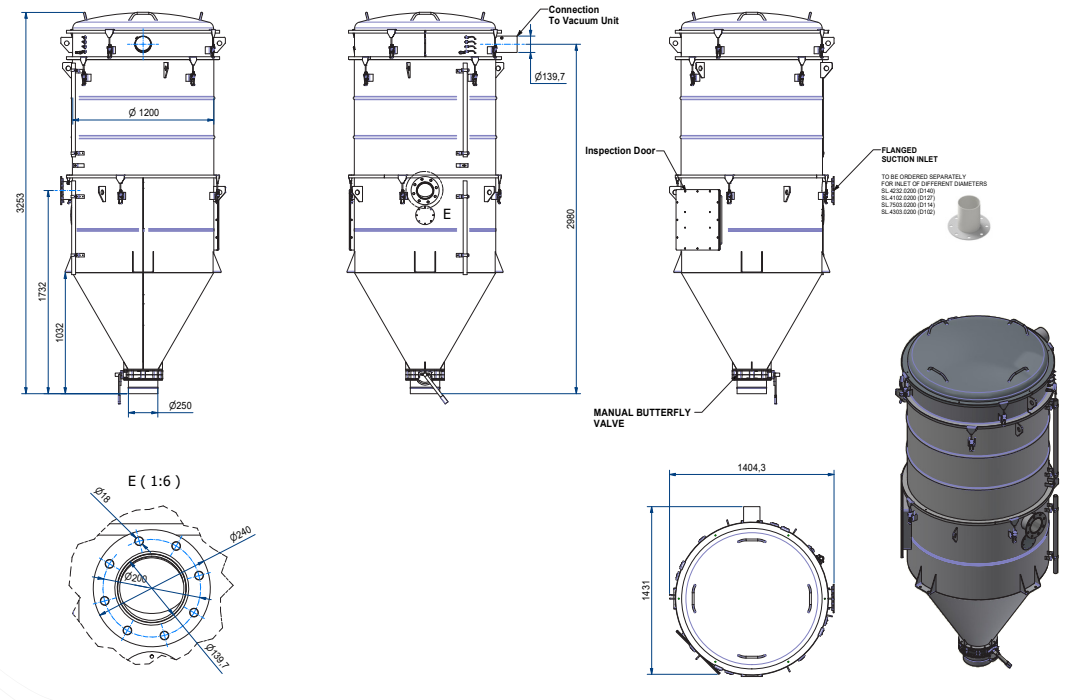

MACHINE CODE	DESCRIPTION
SEP.DLF-0089	Filter separator $\phi 1200$ 16m ² 1000L

All data mentioned in this document is subject to change without notice. All data contained in this document is subject to change without notice.

DELFIN
FOR A DUST-FREE WORLD

www.delfinvacuums.com
delfin@delfinvacuums.it