

FILTER HOPPER SQUARE PRESEPARATORS

SQUARE PRESEPARATOR WITH FILTER 1000L WITH PLATFORM AND LADDER

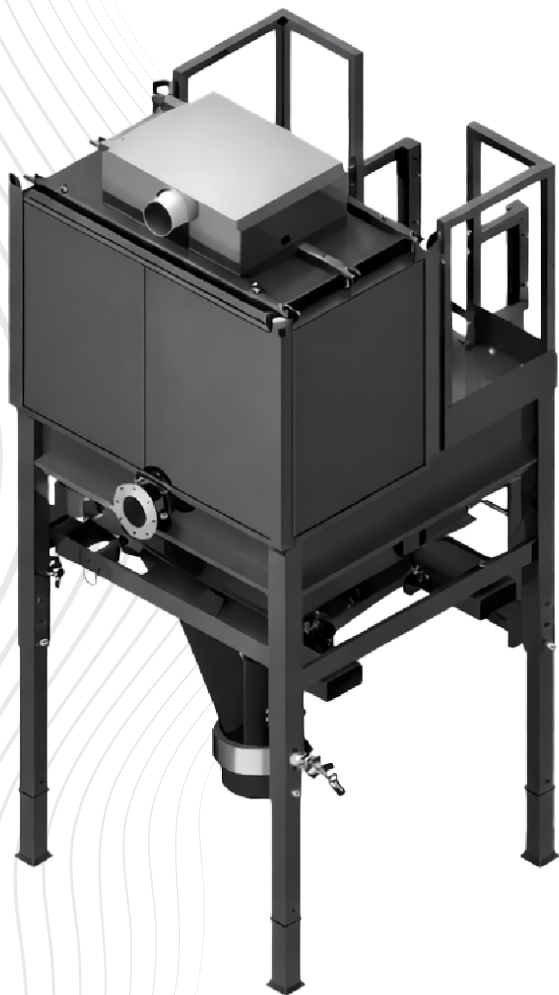

Filter category:



FEATURES

Preseparators with filter sleeves in PTFE and alternating automatic reverse air cleaning

Conical collection hopper with manual butterfly valve D.250 mm and inspection door

Electrical junction box for connection to vacuum unit

Control and maintenance platform with ladder, telescopic legs

Require connection to an external compressed air network

All data mentioned in this document is subject to change without notice. All data contained in this document is subject to change without notice.

DELFIN
FOR A DUST-FREE WORLD
www.delfinvacuums.com
delfin@delfinvacuums.it

COPYRIGHT 2026 DELFIN S.R.L. ALL RIGHTS RESERVED
COPYRIGHT 2026 DELFIN S.R.L. ALL RIGHTS RESERVED

TECHNICAL DATA

 OPTIONAL

		SEP.DLF-0115
Suction inlet diameter	mm	140
Tank capacity	L.	1000
Dimensions	cm	180x160x360h
Primary filter		31 sleeves
Primary filter surface area	cm2	180000
Primary filter media		Polyester
Filter class (IEC 60335-2-69) primary filter		ANT M PTFE
Filter cleaning system		Alternating automatic in backwashing

COPYRIGHT 2026 DELFIN S.R.L. ALL RIGHTS RESERVED
 COPYRIGHT 2026 DELFIN S.R.L. ALL RIGHTS RESERVED

MACHINE CODE	DESCRIPTION
SEP.DLF-0115	Preseparator with walk-on base and ladder

All data mentioned in this document is subject to change without notice. All data contained in this document is subject to change without notice.

DELFIN
 FOR A DUST-FREE WORLD

www.delfinvacuums.com
delfin@delfinvacuums.it