

# TC 600

INDUSTRIAL VACUUM CLEANER FOR MAINTENANCE OF MACHINE TOOLS AND CNC

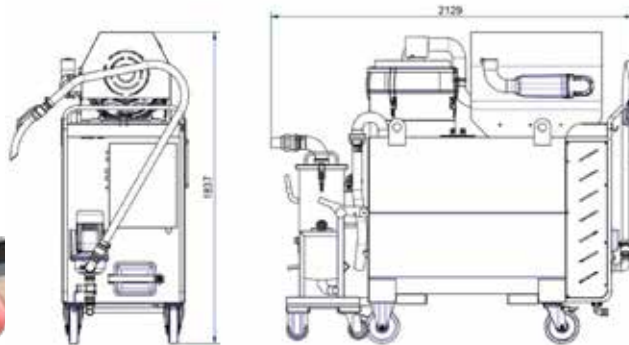

Filter category:

## FEATURES

Separation and recovery of oil and chips for machine tool maintenance  
Easy to transport

Complete painted steel construction

3D superweb kit, sieve grid basket for chip filtration

Reversible flow liquid drain, floating device for overflow, and liquid level indicator tube

All data mentioned in this document may change without notice. All data contained in this document is subject to change without notice.

**DELFIN**  
FOR A DUST-FREE WORLD  
[www.delfinvacuums.com](http://www.delfinvacuums.com)  
[delfin@delfinvacuums.it](mailto:delfin@delfinvacuums.it)

COPYRIGHT 2026 DELFIN S.R.L. ALL RIGHTS RESERVED  
COPYRIGHT 2026 DELFIN S.R.L. ALL RIGHTS RESERVED

## TECHNICAL DATA

		TC600-001
Voltage	V	400
Power	kW	12.6
Frequency	Hz	50
Current draw	A	23.3
Suction inlet diameter	mm	70
Noise level	dB(A)	78
Dimensions	cm	213x75x184h
Weight	kg	405
Electrical protection	IP	65
Liquids capacity	L.	610
Solids capacity	L	75
Discharge capacity		300
Maximum vacuum	mmH2O	5100
Continuous waterlift	mmH2O	4600
Maximum air flow	m <sup>3</sup> /h	520
Motor Type		Three-phase Turbine
Primary filter		3D Superweb
Primary filter diameter	mm	500
Filter class (IEC 60335-2-69) primary filter		Polypropylene
Filtration	µm	20
Discharge system		External pump
Head	mmH <sub>2</sub> O	15
Pump shutdown and automatic drainage		Yes
Automatic pump shutdown control		Yes

## OPTIONAL

Code	Description
PPL300	PPL oil filter kit up to 300 microns (in suction)
OWR	Oil & water repellent cartridge



COPYRIGHT 2026 DELFIN S.R.L. ALL RIGHTS RESERVED  
COPYRIGHT 2026 DELFIN S.R.L. ALL RIGHTS RESERVED

MACHINE CODE	DESCRIPTION
TC600-001	TC 600 IF Kw11

All data mentioned in this document may change without notice. All data contained in this document is subject to change without notice.

**DELFIN**  
FOR A DUST-FREE WORLD

www.delfinvacuums.com  
delfin@delfinvacuums.it