

XTRACTOR3BP-001

THE SINGLE-PHASE INDUSTRIAL VACUUM CLEANER FOR SURFACE TREATMENT

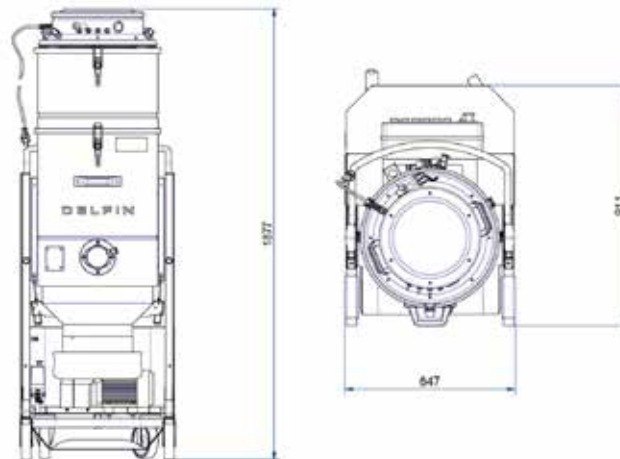

Filter category:



FEATURES

Fine dust

Compact and mobile

Complete painted steel construction

PTFE filter, class M with automatic filter cleaning system

Endless Bag system for safe dust collection and adjustable height to simplify transport on vans

All data mentioned in this document may change without notice. All data contained in this document is subject to change without notice.

DELFIN
FOR A DUST-FREE WORLD
www.delfinvacuums.com
delfin@delfinvacuums.it

COPYRIGHT 2026 DELFIN S.R.L. ALL RIGHTS RESERVED
COPYRIGHT 2026 DELFIN S.R.L. ALL RIGHTS RESERVED

TECHNICAL DATA

		XTRACTOR3BP-001
Voltage	V	230
Power	kW	3.45
Frequency	Hz	50
Current draw	A	15
Suction inlet diameter	mm	80
Tank capacity	L.	20 m Endless bag
Noise level	dB(A)	70
Dimensions	cm	65x91x190 / 164h
Weight	kg	140
Maximum vacuum	mmH2O	2500
Continuous waterlift	mmH2O	2500
Maximum air flow	m ³ /h	540
Motor Type		Single-phase Bypass
Primary filter		Cartridge
Number of cartridges		3
Primary filter load	m ³ (m ² /h)	95
Primary filter surface area	cm ²	57000
Primary filter media		Polyester
Filter class (IEC 60335-2-69) primary filter		M PTFE
Filter cleaning system		PN - automatic compressed air filter cleaning system during
Absolute HEPA Filter		Optional
Filter area of the absolute filter	cm ²	26000
Absolute filter class (EN 1822-5)		H14 with 99.995% efficiency according to the MPPS method

OPTIONAL

Code	Description
H	Additional H14 absolute filter



COPYRIGHT 2026 DELFIN S.R.L. ALL RIGHTS RESERVED
COPYRIGHT 2026 DELFIN S.R.L. ALL RIGHTS RESERVED

MACHINE CODE	DESCRIPTION
XTRACTOR3BP-001	XTRACTOR 3BP LP WITH COMPRESSOR

All data mentioned in this document may change without notice. All data contained in this document is subject to change without notice.

DELFIN
FOR A DUST-FREE WORLD

www.delfinvacuums.com
delfin@delfinvacuums.it