

# XTRACTOR 75 AF

INDUSTRIAL VACUUM CLEANER FOR FINE DUST FOR SURFACE TREATMENT

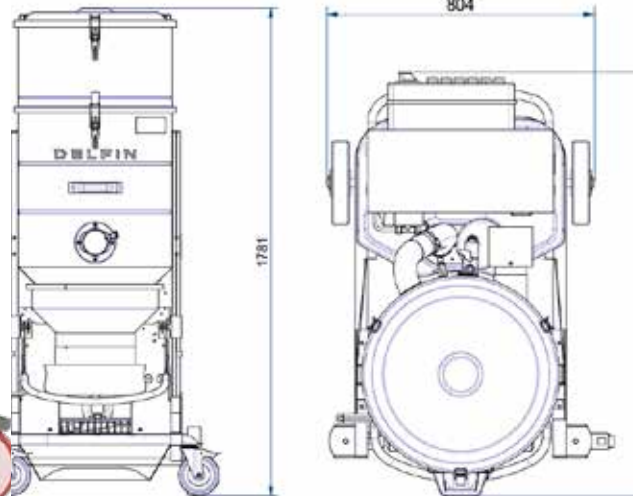

Filter category:



## FEATURES

- Fine dust
- Compact and mobile
- Complete painted steel construction
- PTFE filter, class M with automatic filter cleaning system
- Endless Bag system for safe dust collection

All data mentioned in this document may change without notice. All data contained in this document is subject to change without notice.

**DELFIN**  
FOR A DUST-FREE WORLD  
[www.delfinvacuums.com](http://www.delfinvacuums.com)  
[delfin@delfinvacuums.it](mailto:delfin@delfinvacuums.it)

## TECHNICAL DATA

## OPTIONAL

|  |                                    | XTRACTOR75AF-002  |
|--|------------------------------------|---|
| Voltage                                      | V                                  | 400   |
| Power  | kW                                 | 8.6   |
| Frequency                                    | Hz                                 | 50  |
| Current draw                                 | A                                  | 15.5  |
| Suction inlet diameter                       | mm                                 | 80  |
| Tank capacity                                | L.                                 | 100 / Endless Bag 20 m                                      |
| Noise level                                  | dB(A)                              | 76  |
| Dimensions                                   | cm                                 | 78x127x175h   |
| Weight                                       | kg                                 | 215   |
| Electrical protection                        | IP                                 | 65  |
| Maximum vacuum                               | mmH2O                              | 4000  |
| Minimum vacuum                               | mmH2O                              | 2700  |
| Continuous waterlift                         | mmH2O                              | 2900  |
| Maximum air flow                             | m <sup>3</sup> /h                  | 700   |
| Motor Type                                   |                                    | Three-phase Turbine   |
| Primary filter                               |                                    | Cartridge   |
| Number of cartridges                         |                                    | 4   |
| Primary filter load                          | m <sup>3</sup> (m <sup>2</sup> /h) | 88  |
| Primary filter surface area                  | cm <sup>2</sup>                    | 8000  |
| Primary filter media                         |                                    | Polyester   |
| Filter class (IEC 60335-2-69) primary filter |                                    | M PTFE  |
| Filter cleaning system                       |                                    | PN - automatic compressed air filter cleaning system during |
| Absolute HEPA Filter                         |                                    | Optional  |
| Filter area of the absolute filter           | cm <sup>2</sup>                    | 52000   |
| Absolute filter class (EN 1822-5)            |                                    | H14 with 99.995% efficiency according to the MPPS method    |
| Pressure relief valve                        |                                    | Included  |

| Code | Description                    |
|------|--------------------------------|
| H    | Additional H14 absolute filter |



| MACHINE CODE     | DESCRIPTION                          |
|------------------|--------------------------------------|
| XTRACTOR75AF-002 | XTRACTOR 75 AF 100LT With compressor |

All data mentioned in this document may change without notice. All data contained in this document is subject to change without notice.

COPYRIGHT 2026 DELFIN S.R.L. ALL RIGHTS RESERVED  
COPYRIGHT 2026 DELFIN S.R.L. ALL RIGHTS RESERVED

**DELFIN**  
FOR A DUST-FREE WORLD

www.delfinvacuums.com  
delfin@delfinvacuums.it