

# ZFR CUBE 10

INDUSTRIAL DUST COLLECTOR FOR FINE DUST SUSPENDED IN THE AIR

Filter category:

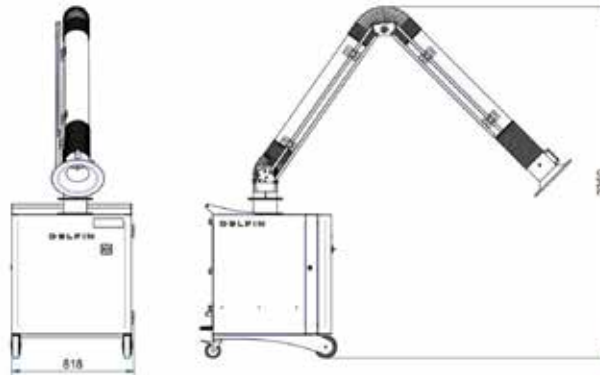

## FEATURES

For fine dust suspended in the air

Easy to transport

Complete painted steel construction

Antistatic polyester class M

High air flow dust collector with adjustable arm

COPYRIGHT 2026 DELFIN S.R.L. ALL RIGHTS RESERVED  
COPYRIGHT 2026 DELFIN S.R.L. ALL RIGHTS RESERVED

## TECHNICAL DATA

|  |                   | ZFRCUBE10-001 |
|--|-------------------|---------------|
| Voltage                                      | V                 | 400           |
| Power  | kW                | 1.1           |
| Frequency                                    | Hz                | 50            |
| Current draw                                 | A                 | 2.38          |
| Suction inlet diameter                       | mm                | 150           |
| Tank capacity                                | L.                | 5             |
| Noise level                                  | dB(A)             | 69            |
| Dimensions                                   | cm                | 90x80x110h    |
| Weight                                       | kg                | 145           |
| Maximum vacuum                               | mmH2O             | 144           |
| Minimum vacuum                               | mmH2O             | 121           |
| Continuous waterlift                         | mmH2O             | 144           |
| Maximum air flow                             | m <sup>3</sup> /h | 2100          |
| Motor Type                                   |                   | Electric fan  |
| Primary filter                               |                   | Cartridge     |
| Primary filter surface area                  | cm <sup>2</sup>   | 10            |
| Primary filter media                         |                   | Polyester     |
| Filter class (IEC 60335-2-69) primary filter |                   | ANT M         |

## OPTIONAL

| Code | Description                    |
|------|--------------------------------|
| H    | Additional H14 absolute filter |



COPYRIGHT 2026 DELFIN S.R.L. ALL RIGHTS RESERVED  
 COPYRIGHT 2026 DELFIN S.R.L. ALL RIGHTS RESERVED

| MACHINE CODE  | DESCRIPTION                            |
|---------------|--|
| ZFRCUBE10-001 | ZEFIRO CUBE 10 with flexible ø150x3000 |

All data mentioned in this document may change without notice. All data contained in this document is subject to change without notice.

**DELFIN**  
FOR A DUST-FREE WORLD

www.delfinvacuums.com  
delfin@delfinvacuums.it