

ZFR CUBE 10 PN

INDUSTRIAL DUST COLLECTOR FOR FINE DUST SUSPENDED IN THE AIR

Filter category:

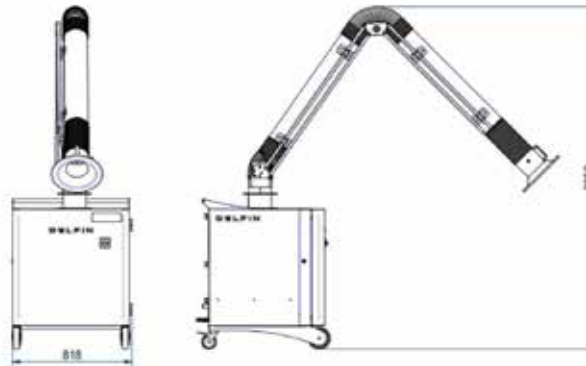

FEATURES

For fine dust suspended in the air

Easy to transport

Complete painted steel construction

Antistatic polyester class M

High air flow dust collector with adjustable arm

COPYRIGHT 2026 DELFIN S.R.L. ALL RIGHTS RESERVED
COPYRIGHT 2026 DELFIN S.R.L. ALL RIGHTS RESERVED

All data mentioned in this document may change without notice. All data contained in this document is subject to change without notice.

DELFIN
FOR A DUST-FREE WORLD
www.delfinvacuums.com
delfin@delfinvacuums.it

TECHNICAL DATA

		ZFRCUBE10PN-001
Voltage	V	400
Power	kW	1.1
Frequency	Hz	50
Current draw	A	2.38
Suction inlet diameter	mm	150
Tank capacity	L.	5
Noise level	dB(A)	69
Dimensions	cm	90x80x110h
Weight	kg	145
Maximum vacuum	mmH2O	144
Minimum vacuum	mmH2O	121
Continuous waterlift	mmH2O	144
Maximum air flow	m ³ /h	2100
Motor Type		Electric fan
Primary filter		Cartridge
Primary filter surface area	cm2	10
Primary filter media		Polyester
Filter class (IEC 60335-2-69) primary filter		ANT M

OPTIONAL

Code	Description
H	Additional H14 absolute filter



MACHINE CODE	DESCRIPTION
ZFRCUBE10PN-001	ZEFIRO CUBE 10 PN with flexible ø150x3000

All data mentioned in this document may change without notice. All data contained in this document is subject to change without notice.

COPYRIGHT 2026 DELFIN S.R.L. ALL RIGHTS RESERVED
COPYRIGHT 2026 DELFIN S.R.L. ALL RIGHTS RESERVED

DELFIN
FOR A DUST-FREE WORLD

www.delfinvacuums.com
delfin@delfinvacuums.it