

MTL 202 ACD LP

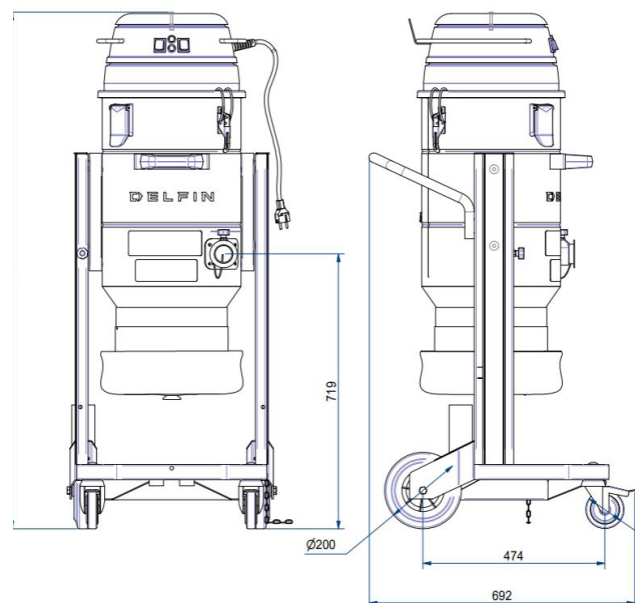

Filter category:



CARATTERISTICHE

Polveri e solidi

Compatto e facile da trasportare

versione con sistema di scarico endless bag

Classe M antistatico, sistema Dustop di pulizia filtro integrato

Testata Ex tb Dust Tight IP64 certificata, accessori e parti non metalliche ATEX testate

All data mentioned in this document may change without notice. All data contained in this document is subject to change without notice.

DELFIN
FOR A DUST-FREE WORLD
www.delfinvacuums.com
delfin@delfinvacuums.it

COPYRIGHT 2026 DELFIN S.R.L. ALL RIGHTS RESERVED
COPYRIGHT 2026 DELFIN S.R.L. ALL RIGHTS RESERVED

DATI TECNICI

 OPTIONAL

		MTL202ACD-001
Zona utilizzo		Ambiente non Classificato
Marcatura		II 1/-D Ex h IIIC T80°C (Internal) Da/-
Categoria EX		1/- D (ACD)
Voltaggio	V	230
Potenza	kW	2.2
Frequenza	Hz	50/60
Assorbimento	A	10
Diametro Bocchettone	mm	50
Capacità Contenitore	lt.	20
Rumorosità	dB(A)	74
Dimensione	cm	51x57x104h
Peso	kg	35
Depressione massima	mmH2O	2500
Depressione in continuo	mmH2O	2500
Portata d'aria massima	m3/h	360
Tipologia Motore		Bypass Monofase
Filtro Primario		cartuccia
Carico sul filtro primario	m3(m2/h)	120
Superficie filtrante filtro primario	cm2	30000
Diametro del filtro primario	mm	360
Media filtrante filtro primario		Poliestere
Classe filtrante (IEC 60335-2-69) filtro primario		ANT M
Sistema di pulizia del filtro		Dustop
Filtro assoluto HEPA		Standard
Superficie filtrante del filtro assoluto	cm2	20500
Classe filtrante filtro assoluto (EN 1822-5)		H14 con 99,995% di efficienza secondo il metodo MPPS



COPYRIGHT 2026 DELFIN S.R.L. ALL RIGHTS RESERVED
COPYRIGHT 2026 DELFIN S.R.L. ALL RIGHTS RESERVED

MACHINE CODE	DESCRIPTION
MTL202LPACD-001	MTL 202 LP ACD EX 1/-D 2BP 20M DUSTOP H KIT 40

All data mentioned in this document may change without notice. All data contained in this document is subject to change without notice.

DELFIN
FOR A DUST-FREE WORLD

www.delfinvacuums.com
delfin@delfinvacuums.it